

System 1 (installation example): normatherm fireplace boiler with radiators + under-floor heating + 1 heat storage tank + hot water storage tank (domestic water)

Note:

Our drawing is to be considered as an example for assembly. It is not a substitute for accurate detail planning. It is also to be checked by the customer for function and completeness.

All safety installations requirements are to be observed in accordance with general technical regulations as well as statutory and national guidelines. The installation specifications of the manufacturer are to be abided by.

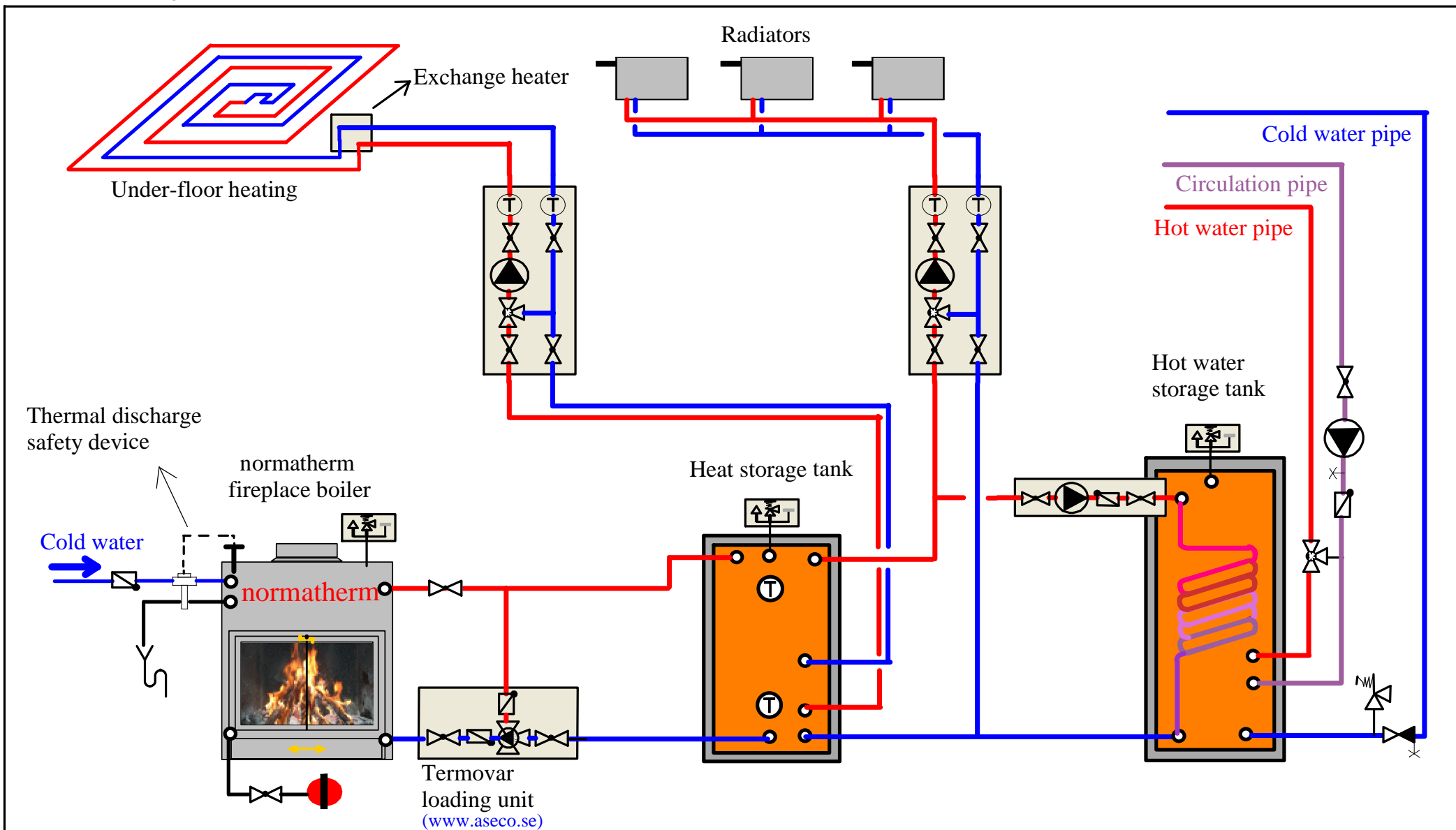

System 2 (installation example): normatherm fireplace boiler with radiators + under-floor heating + 1 gas or oil fired boiler+ 1 hot water storage tank + 1 combination storage tank (solar energy, domestic water)

Note:

Our drawing is to be considered as an example for assembly. It is not a substitute for accurate detail planning. It is also to be checked by the customer for function and completeness.

All safety installations requirements are to be observed in accordance with general technical regulations as well as statutory and national guidelines. The installation specifications of the manufacturer are to be abided by.

